

MEDINA

Pedal operated medical bin



The MEDINA is a 50 litre pedal operated bin designed for medical waste disposal.

The unit has a large waste holding capacity while remaining compact, modern and attractive in design. It is pedal operated to ensure maximum hygiene and a modesty flap ensures waste is not visible to the end user while the unit's large centrally positioned aperture makes waste disposal easy.

The MEDINA incorporates a patent applied removable hygienic bin to aid serviceability. The hygienic bin protects the inside of the unit from soiling and can be removed for easy cleaning.



Finishes available

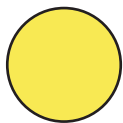

Yellow

Benefits

Ease of Service

- > Removable hygienic bin protects bin from soiling/eases cleaning
- > Designed throughout to minimise dirt traps

Maximum Hygiene

- > Foot pedal for hands-free operation
- > Removable hygienic bin
- > Protects inside of bin from soiling
- > Removes for easy bin cleaning

For extra hygiene

- > Medical bin liners

End user satisfaction & image

- > Large centrally positioned aperture for easy waste disposal
- > Built in odour control system
- > Modesty flap ensures waste inside is not visible
- > Compact, modern and attractive design

For more information
www.kennedy-hygiene.co.uk

MEDINA

Pedal operated medical bin



Packaging info

	Plt. Table	Packed	Qty Per	Weight/kg	Measurement in cm
The MEDINA	Std. Plt	Carton	1	6	44 x 37.5 x 53
		Pallet	18	113	120 x 100 x 200

Technical drawings

Materials: constructed mainly from ABS. Dispenser can be recycled or disposed of in accordance with local regulations.

Packing: One unit is packed into a double wall carton.

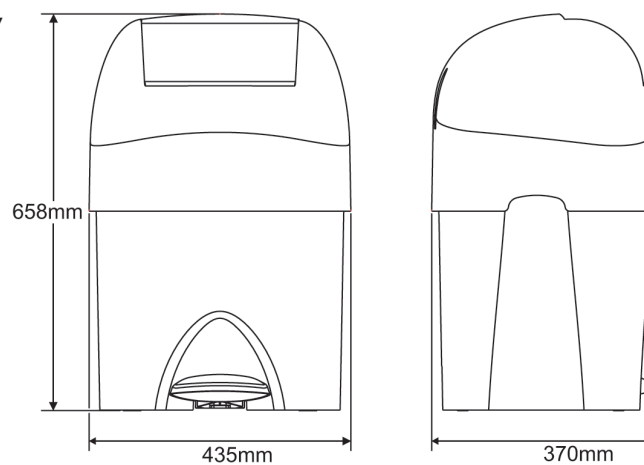

Consumables

> Medical bin liners

Kennedy Hygiene Products Limited

Brookside
Uckfield
East Sussex TN22 1YA
United Kingdom

T +44 (0) 1825 768141
F +44 (0) 1825 768143
E sales@kennedy-hygiene.com

